

ASSEMBLY INSTRUCTIONS

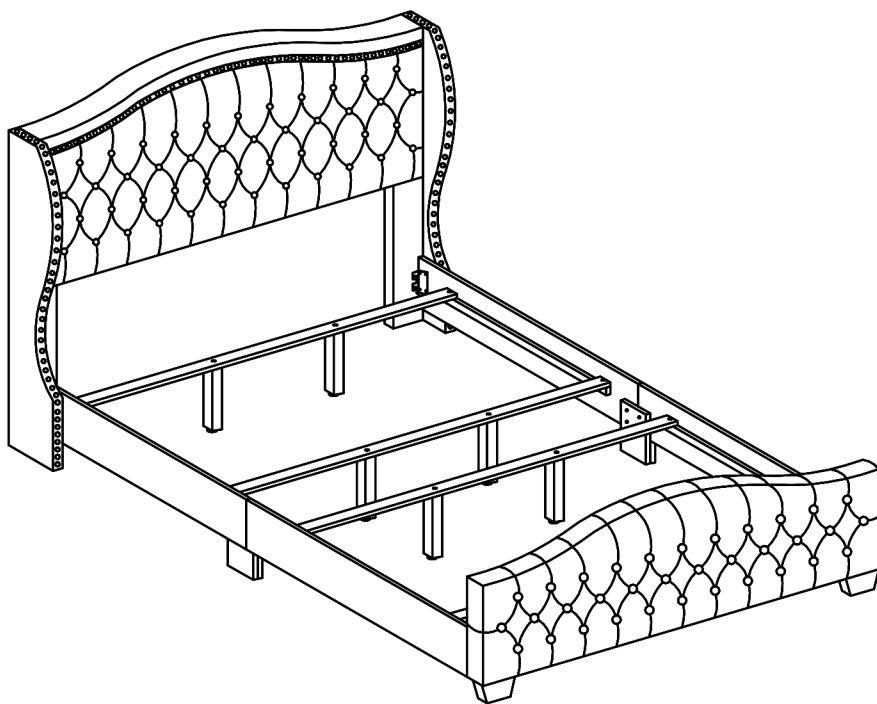

TOOLS REQUIRED

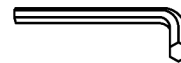

Allen Wrench

(Included)

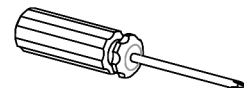

Phillips Screwdriver

(Not Included)



3 - People Recommended

ASSEMBLY RATING



EASY → DIFFICULT

The Assembly Rating is a 5-point system showing the level of effort needed to assemble a specific product.



CHECK BEFORE STARTING

Are you missing anything?

Double-check all parts, hardware and accessories listed are all accounted for.

Check out our Quick Tips!

We recommend reviewing the pre-assembly handouts. Even experts need a refresher now and then!

Should we send any replacements?

Are there any irregularities or flaws in the parts? We can send replacements!

Prep Time!

Please review the assembly instructions and all diagrams prior to assembling.

PRE ASSEMBLY INTRODUCTION

We understand building ready-to-assemble furniture can be a challenging experience for some. To help avoid confusion, we have provided some helpful tips that may speed up the process.

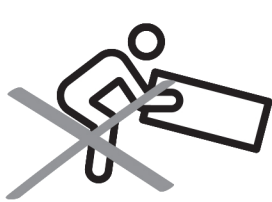

Teamwork

ALWAYS have at least two people to help with transporting and assembling the product to avoid potential injury and/or damage.

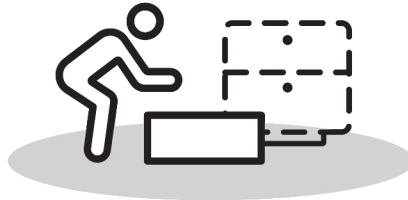
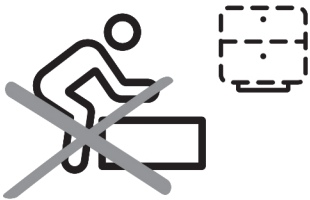

Suitable Location

Assembling near the area of the intended location is highly recommended.



Sufficient Space

Make sure you have enough space to move around during the assembly.



Avoid Scratches

Use cardboard, blankets or a carpeted area while assembling furniture to prevent to prevent scratches and damages.

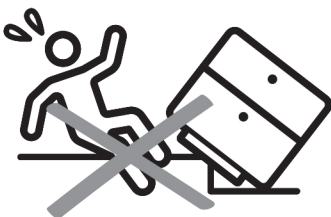

Flat Surface

Make sure the furniture rests on a flat and level surface with each leg evenly touching the floor.

ASSEMBLY AND CARE ADVICE



FAILURE TO FOLLOW THE GUIDELINES BELOW MAY RESULT IN INJURY AND/OR PROPERTY DAMAGE.



Position each part correctly and insert screws or bolts into their respective holes.

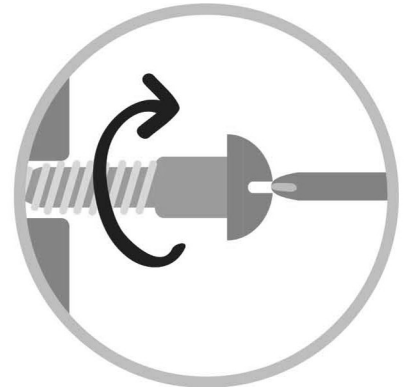

Turn clockwise to tighten and only tighten when step is completed or when instructed to do so.



Save the instructions and store any supplied tools for later maintenance.

Use the appropriate hand tools or power tools for assembly. Select steps, such as tightening screws and/or bolts, may require hand tools to avoid causing damage during assembly.



After two weeks, check and tighten any loose hardware and repeat again every six months thereafter.

IT IS THE USER'S RESPONSIBILITY TO MAINTAIN THE FURNITURE. THE HARDWARE MAY LOOSEN OVER TIME AND MAY CAUSE THE FURNITURE TO BE WOBBLY AND UNABLE TO SUPPORT ITS INTENDED WEIGHT CAPACITY. THIS MAY LEAD TO COLLAPSE AND MAY CAUSE SERIOUS INJURY.

EASTERN KING BED



• Please keep instructions for future reference.
• Check the quantity and irregularity of parts and hardware before you start.

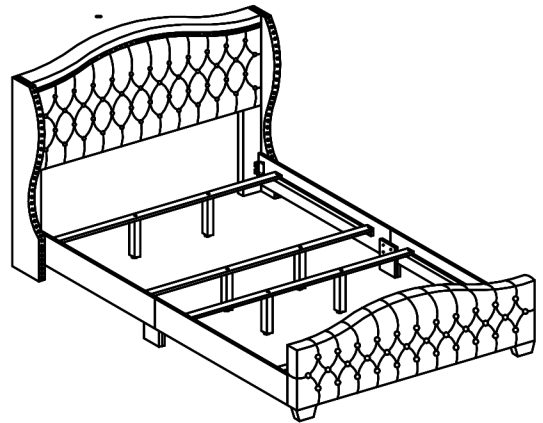

PARTS

#1 x 1pc

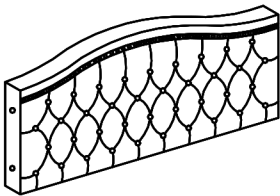

Headboard

#2 x 1pc

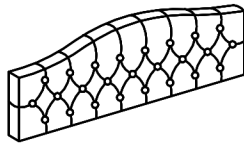

Footboard

#3 x 2pcs

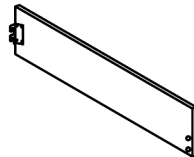

Side Rail (L)

#4 x 2pcs

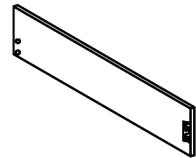

Side Rail (R)

#5 x 2pcs

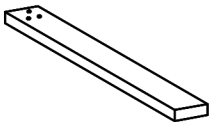

Headboard Leg

#6 x 2pcs

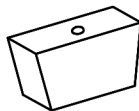

Footboard Leg

#7 x 2pcs

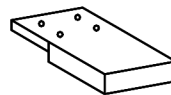

Side Rail Support Leg

#8 x 4pcs



Side Rail Support

#9 x 4pcs

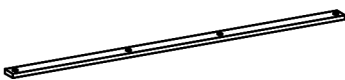

Bed Slat
1947x45x18 mm

#10 x 8pcs



Bed Slat Support
170x30x30mm

#11 x 1pc



Side Wing (L)

#12 x 1pc



Side Wing (R)

HARDWARE

#A x 8pcs

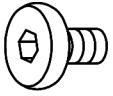

JCBB M8x20mm

#B x 20pcs

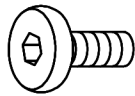

JCBC M6x30mm

#C x 12pcs

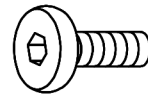

JCBC M6x40mm

#D x 8pcs

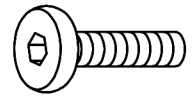

JCBC M6x50mm

#E x 1pc



Allen Wrench
M4 x 100mm

#F x 1pc



Allen Wrench
M5 x 70mm

#G x 8pcs



CSK Screw 32mm

#H x 10pcs



Spring Washer

#I x 12pcs



Flat Washer

#J x 8pcs

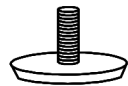

Adjuster

ASSEMBLY INSTRUCTIONS

1

Remove parts located within the hidden compartment behind headboard (#1).

Part #1 x1pc

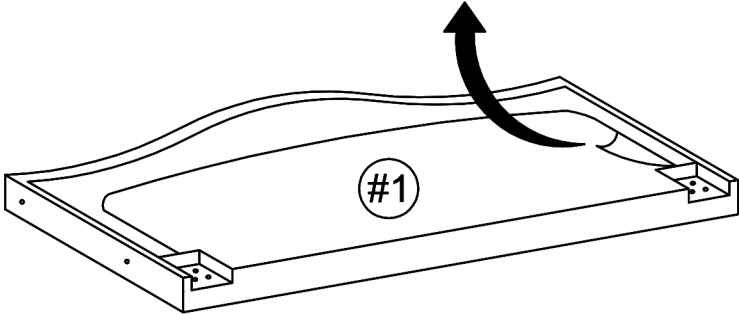

Attention: Zip the black non-woven fabric after take out the parts !!

BACK VIEW

2

- Part #2 x1pc
- Part #5 x2pcs
- Part #6 x2pcs
- Part #11 x1pc
- Part #12 x1pc
- Hardware #C x4pcs
- Hardware #D x8pcs
- Hardware #E x1pc
- Hardware #H x10pcs
- Hardware #I x4pcs

1. Align footboard legs (#6) to the footboard (#2), secure using bolts (#E).

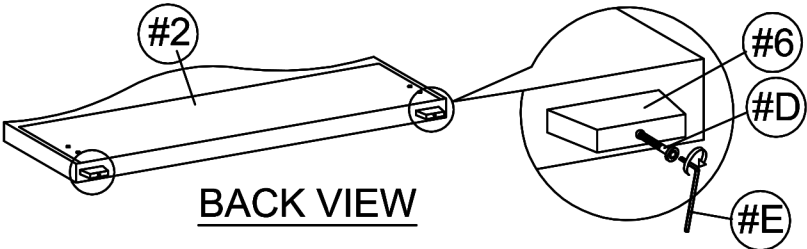

BACK VIEW

2. Align headboard legs (#5) to the headboard (#1), then secure using bolts (#D) with washer (#H).

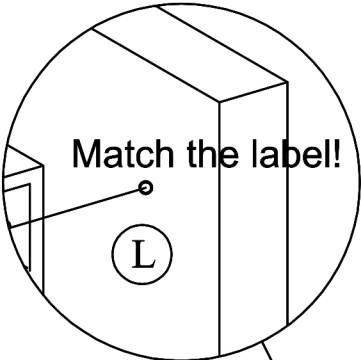

3. Align and attach wings (#11,12) to the headboard (#1), secure using bolts (#C) with washers (#H,I).

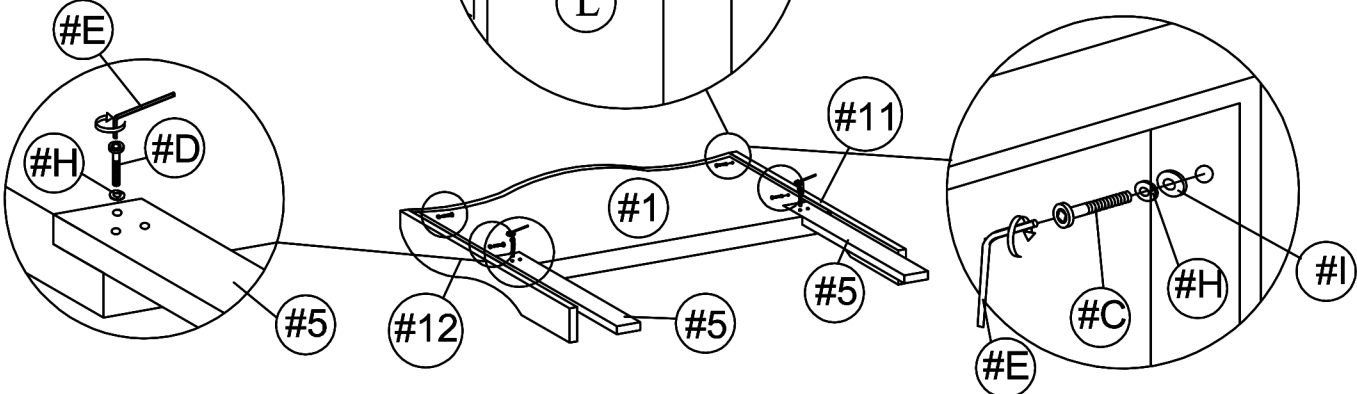

BACK VIEW

ASSEMBLY INSTRUCTIONS

3

Attach bolts (#A) to footboard (#2) and headboard (#1).

Hardware (#A) x8pcs

Hardware (#F) x1pc

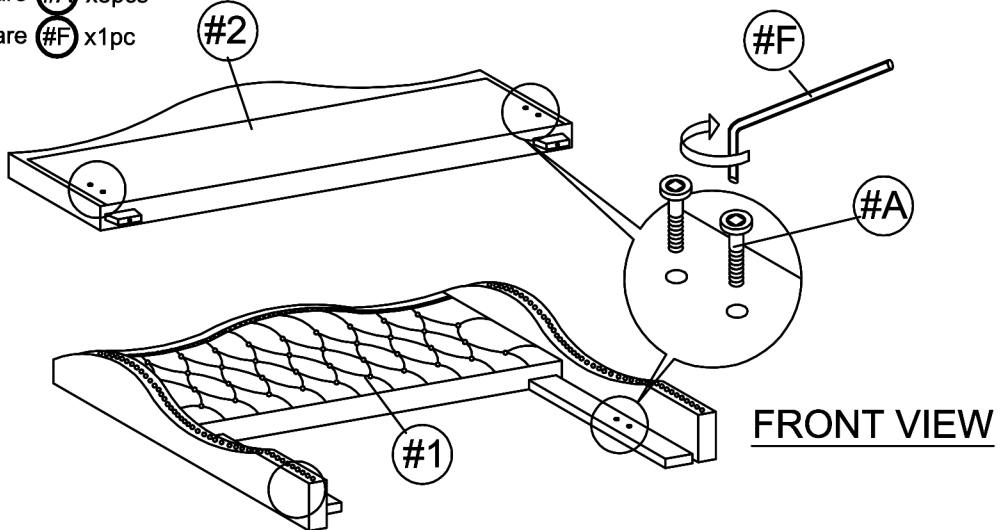

4

Align and attach rail supports (#8) to the side rails (#3,4) using bolts (#B).

Part (#3) x2pcs

Part (#4) x2pcs

Part (#8) x4pcs

Hardware (#B) x12pcs

Hardware (#E) x1pc

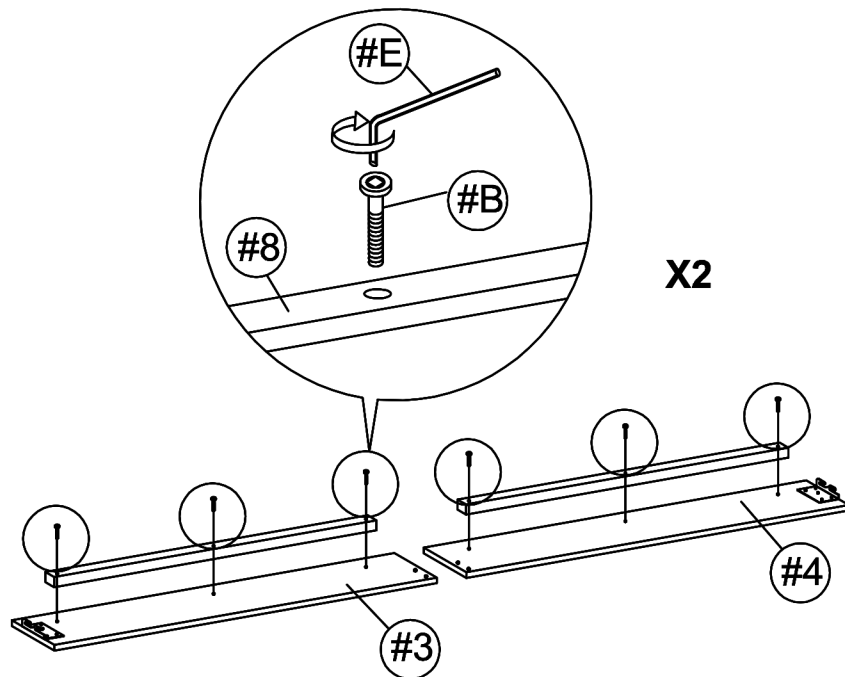

ASSEMBLY INSTRUCTIONS

5

Align rail support legs (#7) over side rails (#3,4), then secure using bolts (#B) with washers (#I).

- Part (#7) x2pcs
- Hardware (#B) x8pcs
- Hardware (#E) x1pc
- Hardware (#I) x8pcs

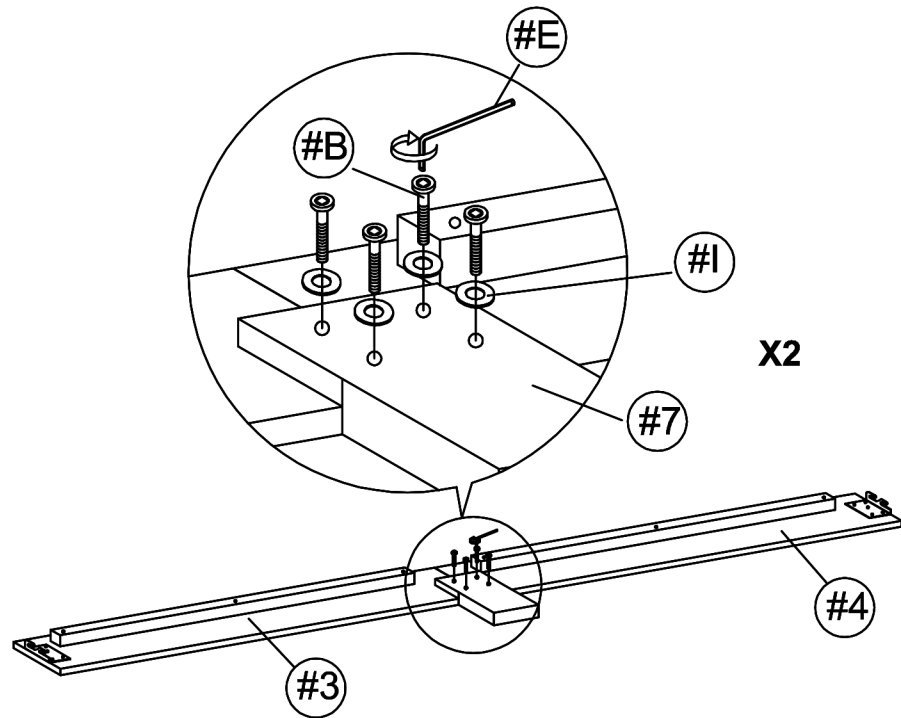

6

Hook side rails to the headboard (#1) and footboard (#2).

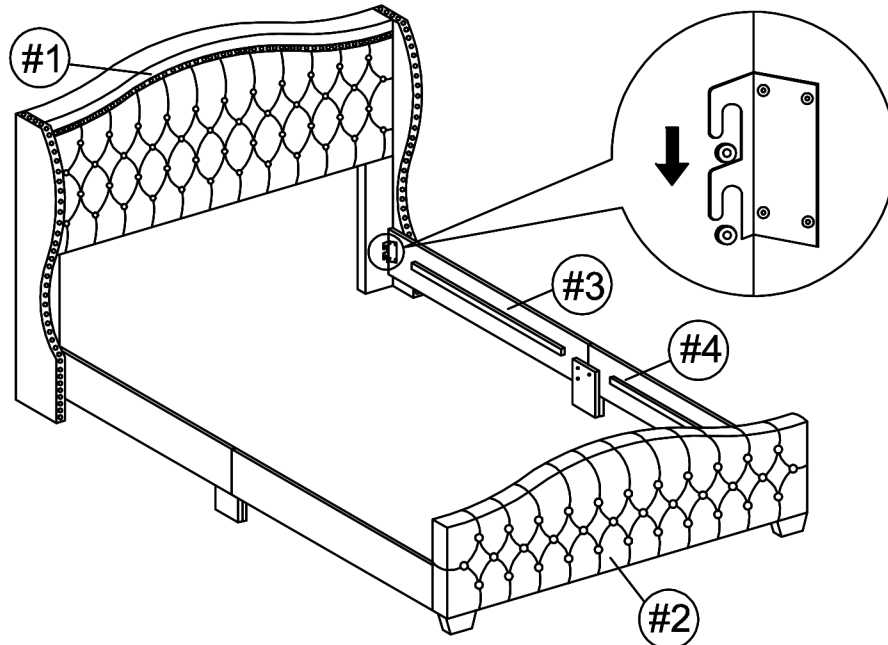

ASSEMBLY INSTRUCTIONS

7

Attach adjusters (#J) to the bottom of slat support legs (#10). Attach support legs (#10) to the bed slats (#9). Adjust levelers on the support legs according to Ground level.

- Part #9 x4pcs
- Part #10 x8pcs
- Hardware #C x8pcs
- Hardware #E x1pc
- Hardware #J x8pcs

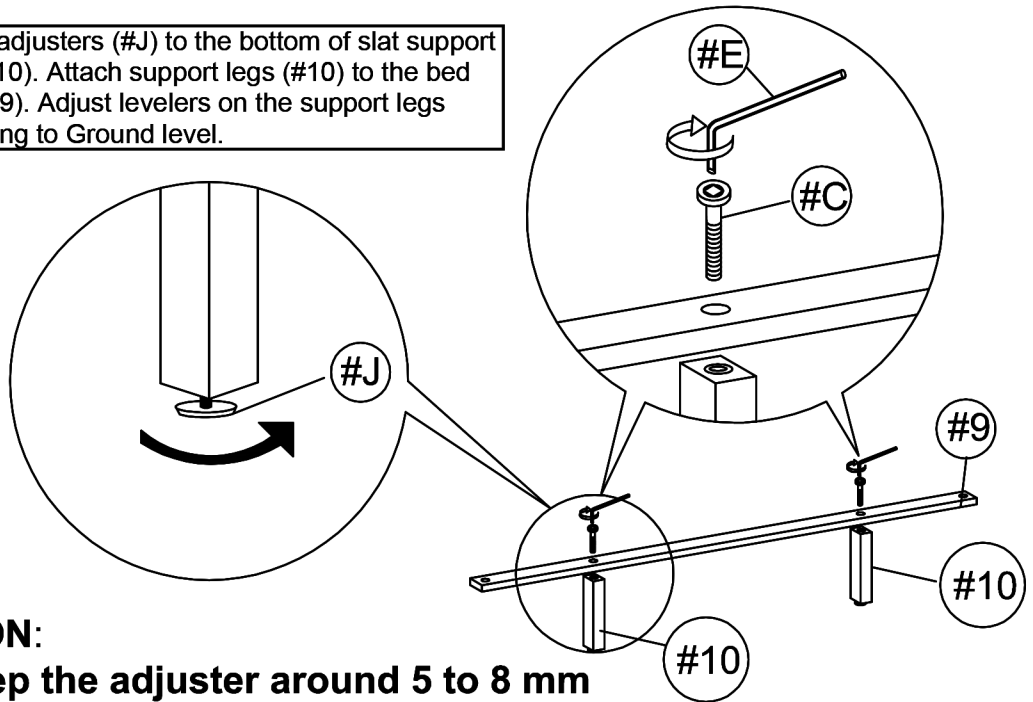

ATTENTION:
Please keep the adjuster around 5 to 8 mm distant away from the floor.

8

- Hardware #F x1pc
- Hardware #G x8pcs

Align slats to the side rails (#9), then secure by using screws (#G).

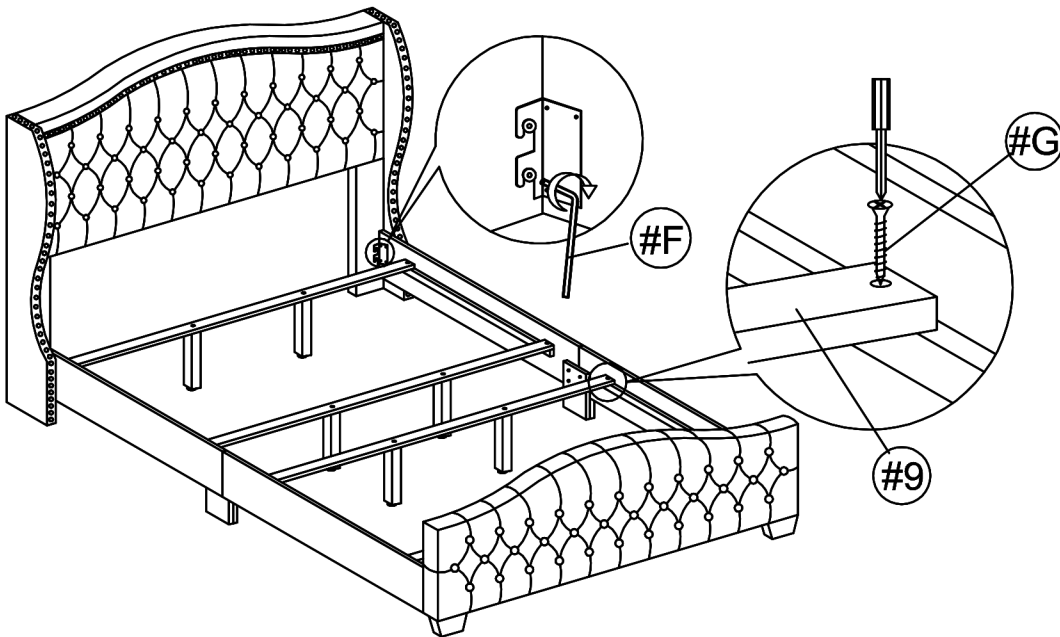

ASSEMBLY COMPLETED

Please ensure the furniture rests on an even and flat surface. If the product wobbles or feels loose, double-check all bolts and/or screws are properly tightened and secured.

- ✓ **Keep this handy!**
Please retain this instruction manual and any order-related information for future reference.
- ✓ **Lift, don't drag!**
To avoid damage to product please always LIFT the product when transporting or adjusting the placement.