

# Assembly Instructions

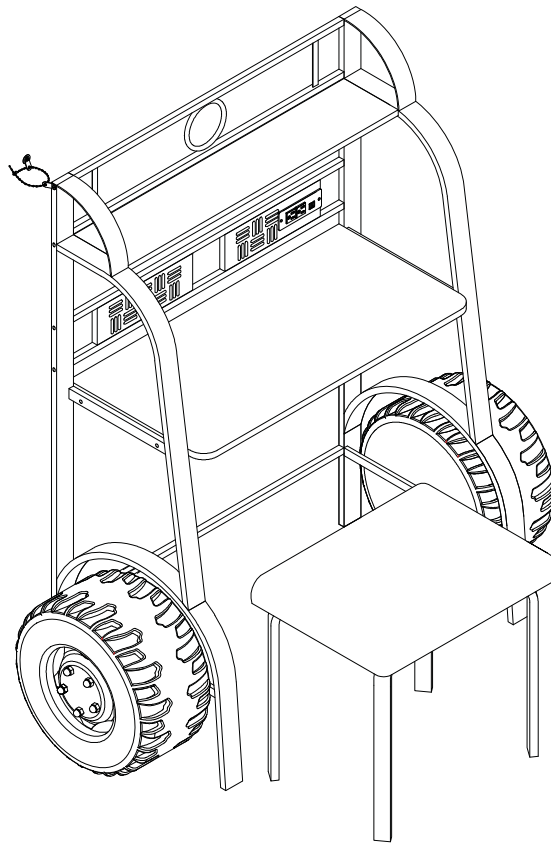

## ASSEMBLY RATING

The Assembly Rating is a 5-point system that shows the degree of effort needed in assembling a specific product (with 1 being easy and 5 being difficult). For some products, two persons are recommended.



## Tools Required For Assembly:

Allen Wrench

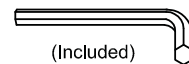

(Included)

Phillips Screwdriver



(Not Included)



2 PERSONS RECOMMENDED

# ASSEMBLY & CARE ADVICE

FOR YOUR FURNITURE TO LAST, CORRECT ASSEMBLY AND PROPER MAINTENANCE ARE NECESSARY. PLEASE FOLLOW THE INFORMATION PROVIDED BELOW TO FULLY ENJOY YOUR FURNITURE.

## BASIC ASSEMBLY TECHNIQUES

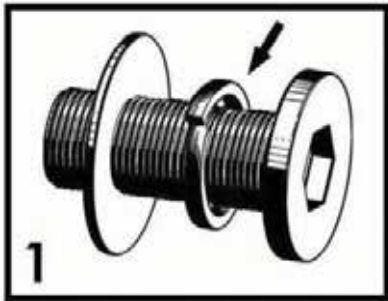

When lock or spring washer is used in an assembly, please make sure the lock or spring washer is placed between the larger flat washer and the head of the screw or bolt.



Position each part correctly and insert screws or bolts into their respective holes by hand tighten or using the proper hand tool. Only tighten when step is completed or when instructed to do so.



Use cardboard or carpet area when assembling furniture to prevent scratches. Make sure the furniture rests on a flat and level surface with each leg evenly touching the floor.

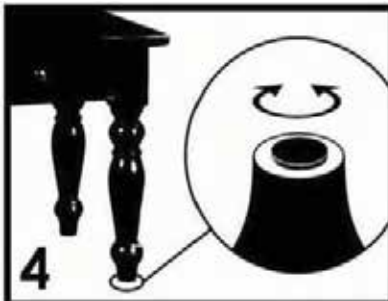

Some furniture comes with height adjustment knobs underneath each leg. To lower or to raise each leg, you need to turn clockwise or counterclockwise, respectively.

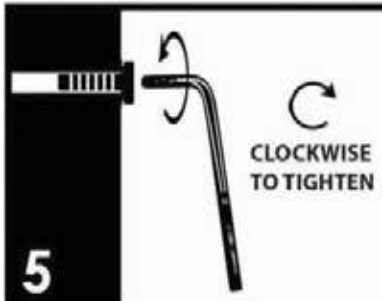

Make sure all parts are properly aligned, then use the appropriate hand tool to completely tighten the bolts or screws. Do not use power tools and do not overtighten.

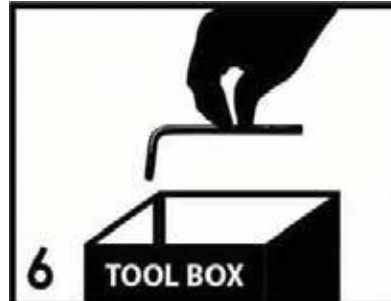

Save the instructions and store the Allen wrench or any supplied tool for later maintenance. After two weeks, check and tighten any loose hardware and repeat again every six months thereafter.

IT IS THE USER'S RESPONSIBILITY TO MAINTAIN THE FURNITURE. THE HARDWARE MAY LOOSEN OVER TIME AND MAY CAUSE THE FURNITURE TO BE WOBBLY AND UNABLE TO SUPPORT ITS INTENDED WEIGHT CAPACITY. THIS MAY LEAD TO COLLAPSE AND MAY CAUSE SERIOUS INJURY.

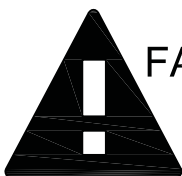

**FAILURE TO FOLLOW THE GUIDELINES ABOVE MAY RESULT IN INJURY AND/OR PROPERTY DAMAGE.**



Before you begin, please read Page 2 of "Assembly and Care Advice".

And remember, do not tighten until each step is completed or instructed.

### Parts List



#1 x 1pc  
Left Support Frame

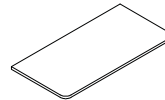

#6 x 1pc  
Desk Top



#2 x 1pc  
Right Support Frame

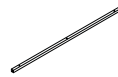

#7 x 2pcs  
Desk top Support Bar

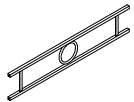

#3 x 1pc  
Up Tube Frame

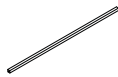

#8 x 1pc  
Bottom Support Bar

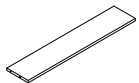

#4 x 1pc  
Small Shelf



#9 x 2pcs  
Wheel



#5 x 1pc  
Middle Tube Frame



#10 x 2pcs  
Wheel Cover

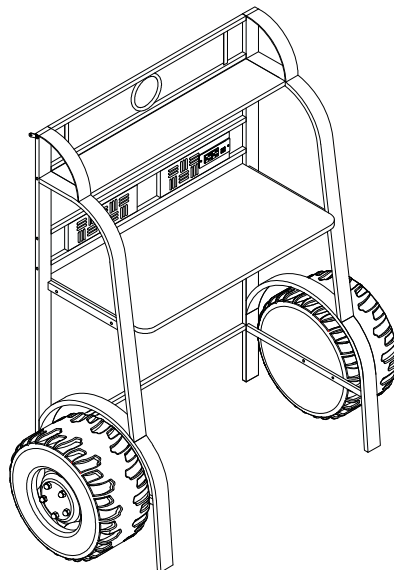



Before you begin, please read Page 2 of "Assembly and Care Advice".

And remember, do not tighten until each step is completed or instructed.

### Hardware List



#A x 4pcs  
Screw M5 x 10MM



#B x 4pcs  
Bolt 1/4" X1-3/8"



#C x 10pcs  
Bolt 1/4" X 3"

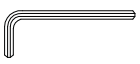

#D x 1pc  
Allen Wrench M4



#E x 8pcs  
Screw M4 x 25MM



#F x 1pc  
Socket



#G x 2pcs  
Screw M3 x 10MM



#H x 2pcs  
Hex Nut



#I x 1pc  
Screw M4 x 37MM



#J x 2pcs  
Keyhole Slot



#K x 1pc  
Explosive nut



#L x 1pc  
Tipping Restraint



#M x 6pcs  
Flat Washer



#N x 2pcs  
Stub Bolt 5/16" X 8-1/2"

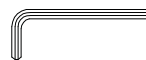

#O x 1pc  
Allen Wrench M5



#P x 2pcs  
Bolt 5/16" X 3/4"



#1

#C x 10pcs  
#J x 1pc

1. Align the up tube frame (#3) to the holes along the top of the left and right support frames (#1,2). Then apply a keyhole slot (#J) into 2 bolts (#C), insert those into the upper holes and insert a bolt (#C) into the lower holes. Secure using the Allen wrench (#D).

2. Align the middle tube frame (#5) to the holes along the center of the left and right support frames (#1,2). Then insert a bolt (#C) into each hole. Secure using the Allen wrench (#D).

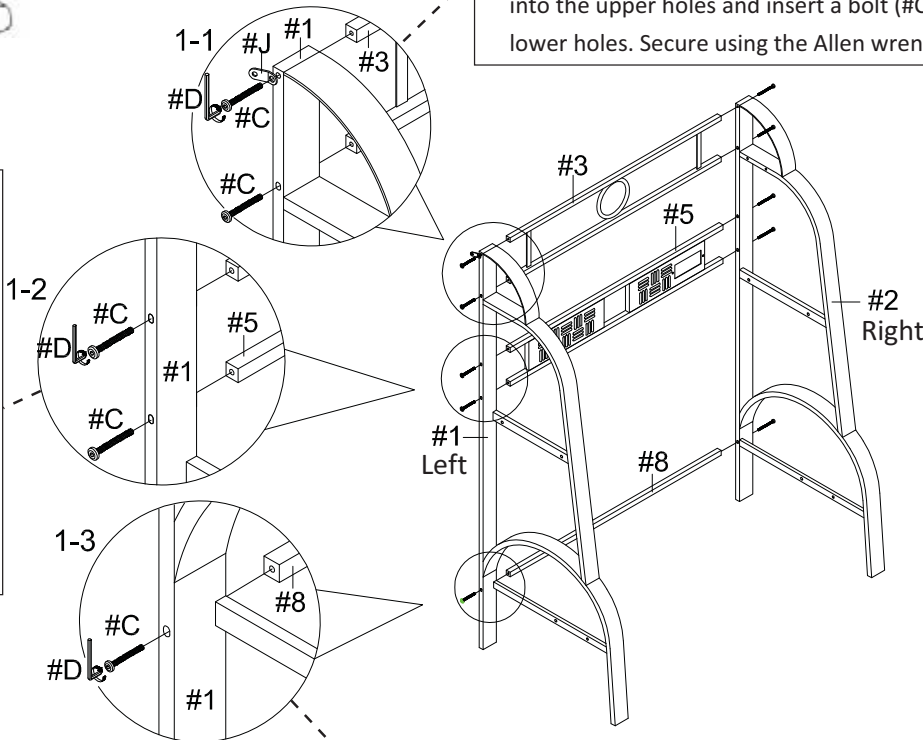

3. Align the bottom support bar (#8) to the holes along the bottom of the left and right support frames (#1,2). Then insert a bolt (#C) into the holes. Secure using the Allen wrench.



#2

#A x 4pcs

Align the small shelf (#4) to the holes along the top of the left and right support frames (#1,2). Then insert 2 screws (#A) into the holes. Secure using a Phillips screwdriver.

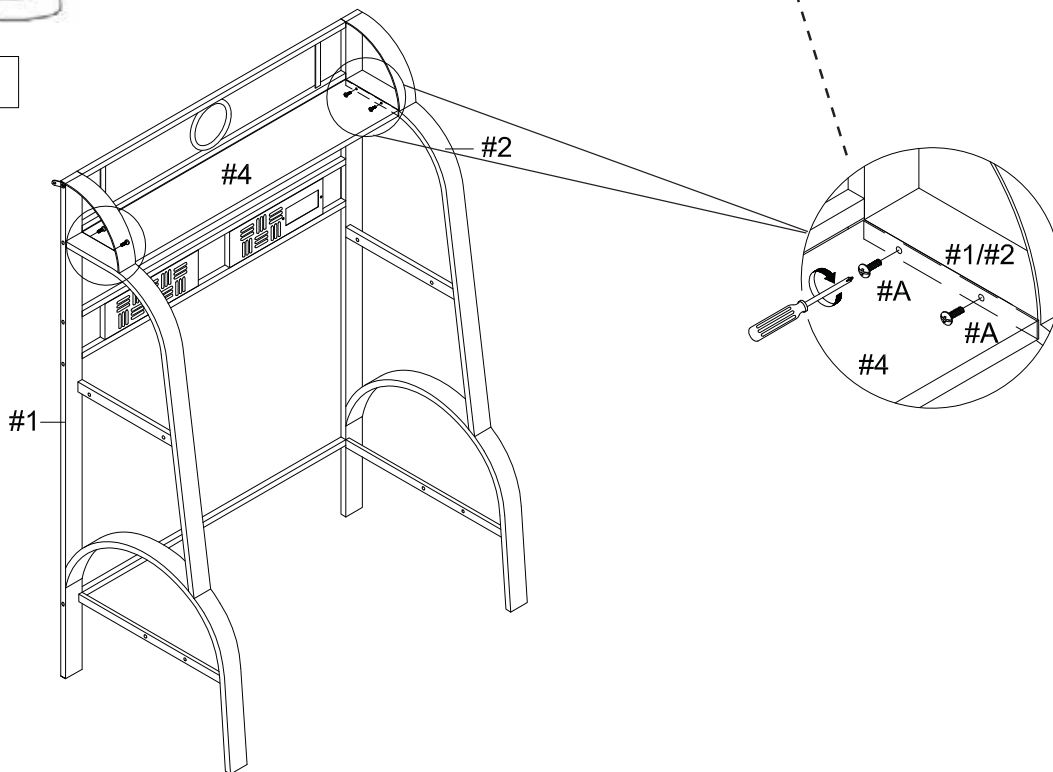



Align the desktop support bars (#7) to the holes along the center of the left and right support frames (#1,2). Then insert a bolt (#B) into each end. Secure using the Allen wrench (#D).

#B x 4pcs

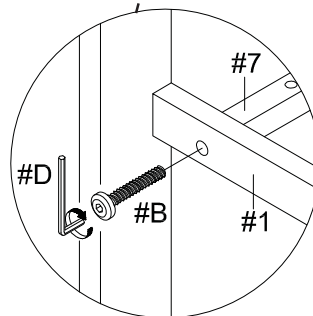
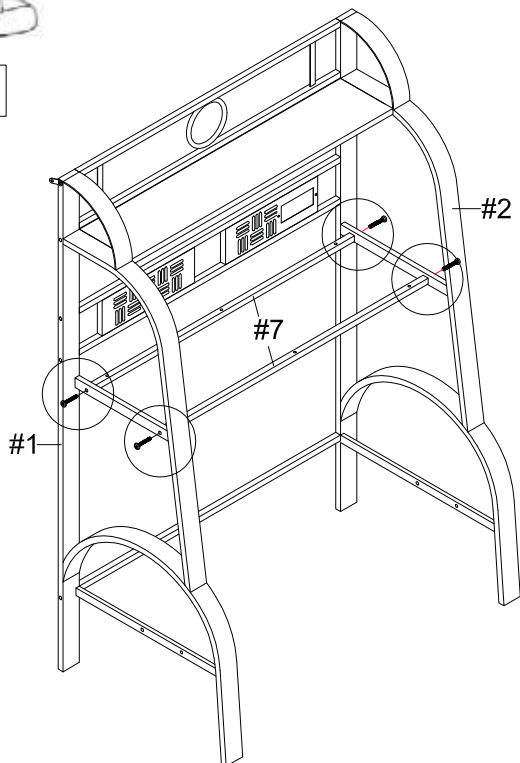

2. Align the socket (#F) to the holes along the middle tube frame (#5), then insert 2 screws (#G) and secure using a Phillips screwdriver. On the other side apply a hex nut (#H) onto each screw and tighten.

#E x 6pcs  
#F x 1pc  
#G x 2pcs  
#H x 2pcs  
#M x 6pcs

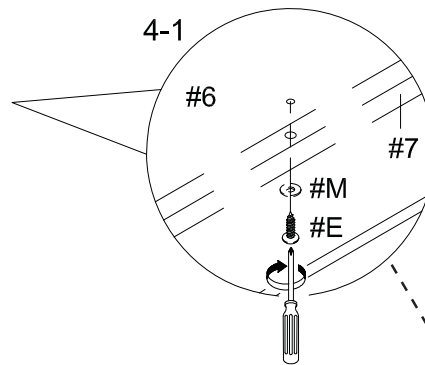
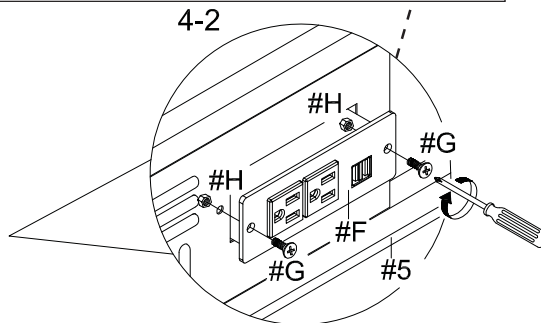
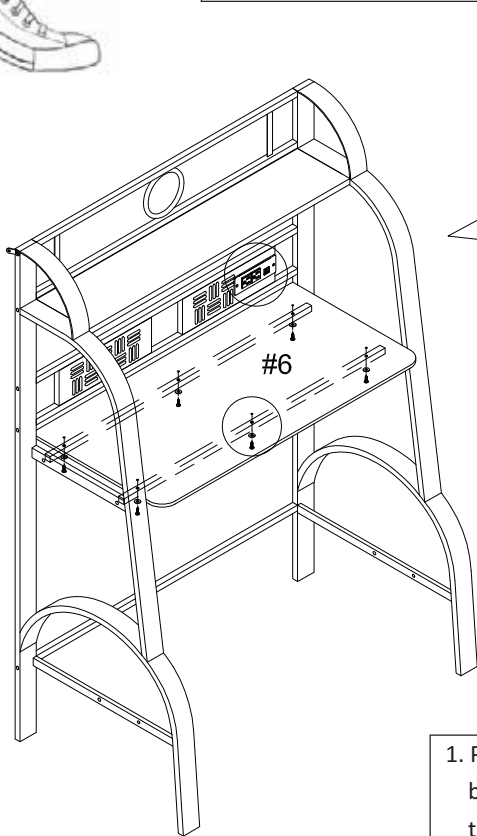

1. Place the desk top (#6) onto the support bars (#7). Then prepare 6 screws by inserting a flat washer (#M) onto the screws (#E), after that insert into the holes from below into the bars and secure using a Phillips screwdriver.



1. Insert a threaded end of the stub bolt (#N) into the wheel cover (#10), turn right to tighten.

#E x 2pcs  
#N x 2pcs  
#P x 2pcs

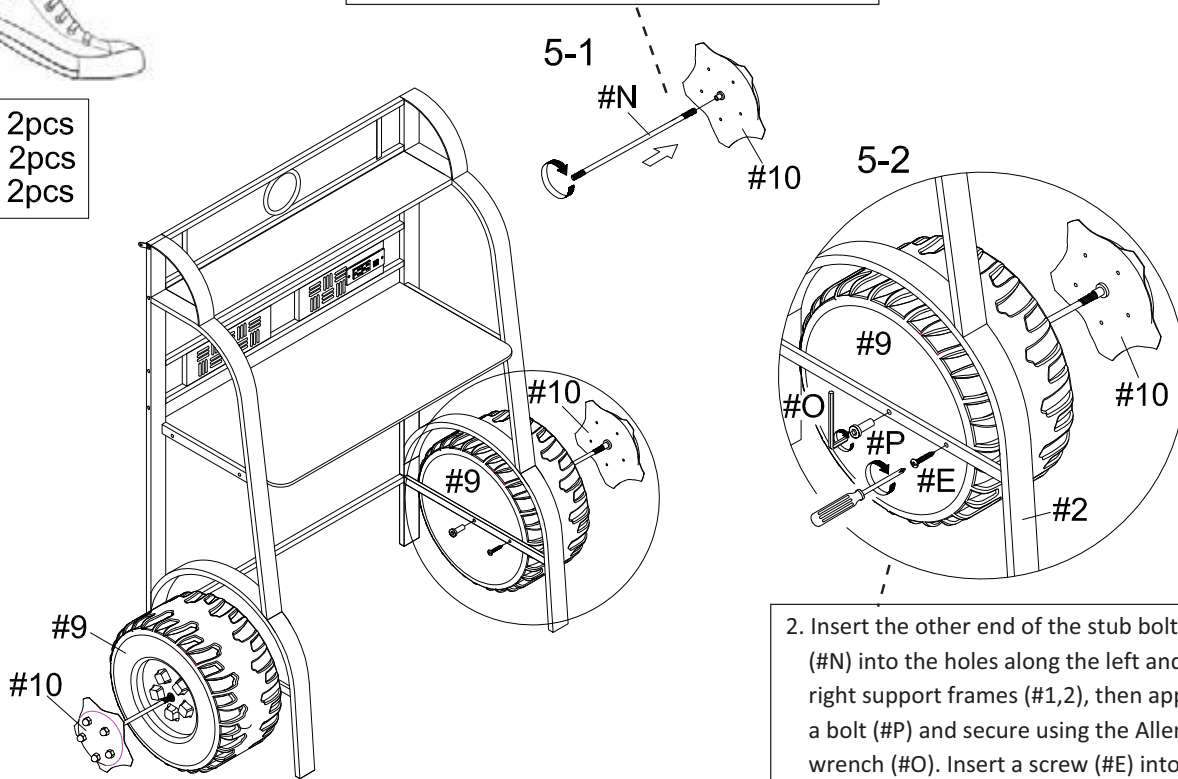

2. Insert the other end of the stub bolt (#N) into the holes along the left and right support frames (#1,2), then apply a bolt (#P) and secure using the Allen wrench (#O). Insert a screw (#E) into the other holes to secure the wheel and secure using a Phillips screwdriver.

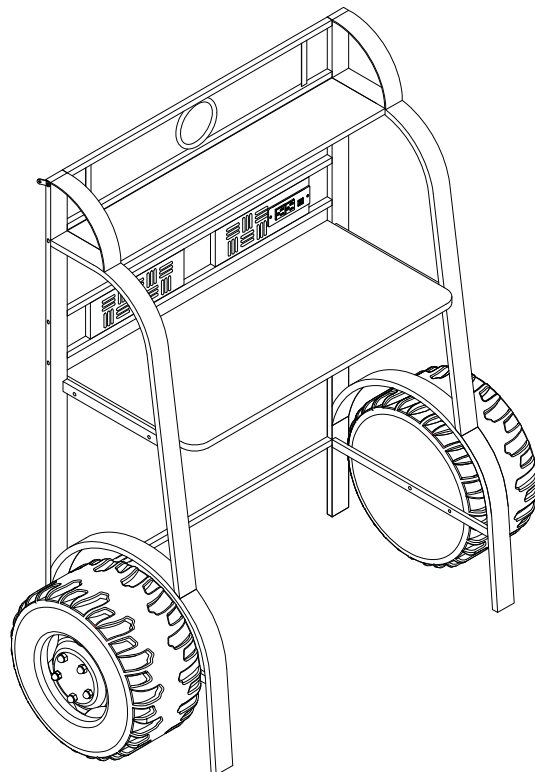

ASSEMBLY IS COMPLETED

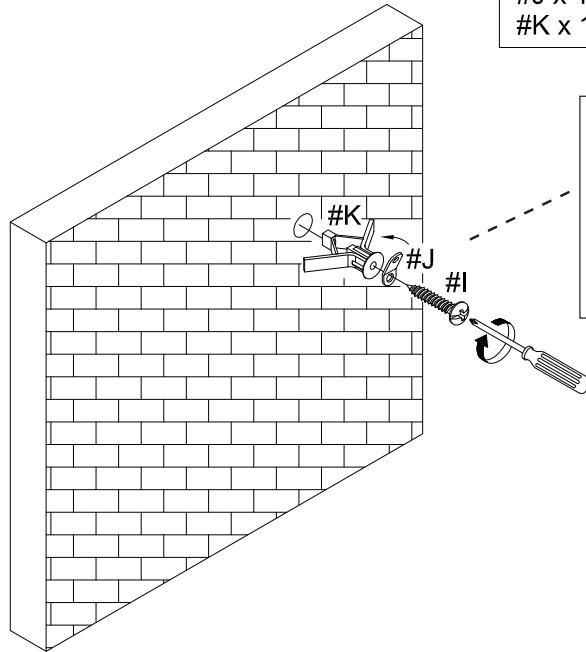

#I x 1pc  
 #J x 1pc  
 #K x 1pc

Drill a hole slightly smaller than the explosive nut (#K), then push the nut (#K) into the hole. After that align a keyhole slot (#J) to the nut and insert a screw (#I). Secure using a Phillips screwdriver.

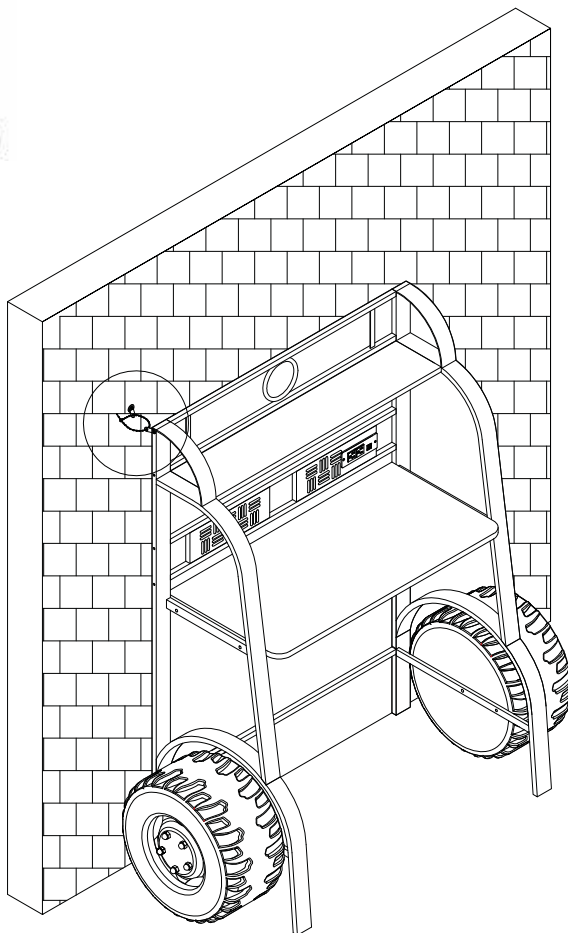

#L x 1pc

To Prevent Tip over  
 Product Must Be  
 Attached To Wall

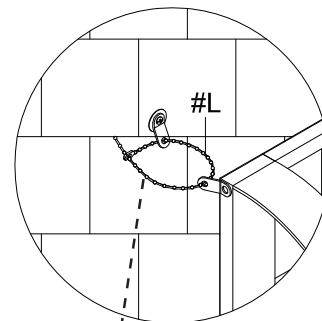



Place the keyhole slots (#J) near each other and insert a tipping restraint (#L). Secure accordingly.





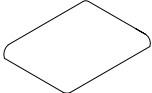
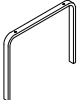

Before you begin, please read Page 2 of "Assembly and Care Advice".

And remember, do not tighten until each step is completed or instructed.

### Parts List

-  #1 x 1pc  
Seat
-  #2 x 1pc  
Leg
-  #3 x 1pc  
Leg

### Hardware List

-  #A x 1pc  
Bolt 1/4" X 3/8"
-  #B x 4pcs  
Bolt 1/4" X 1-1/8"
-  #C x 1pc  
Allen Wrench
-  #D x 4pcs  
Rubber mat

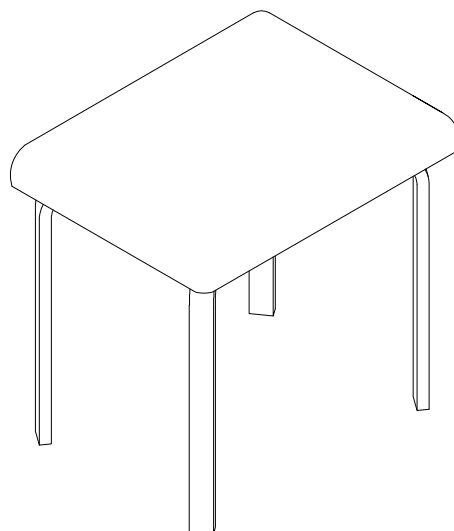



#1

#A x 1pc

Place the legs (#2) and (#3) face down and align the center hole, then insert a bolt (#A) and secure using the Allen wrench (#C).

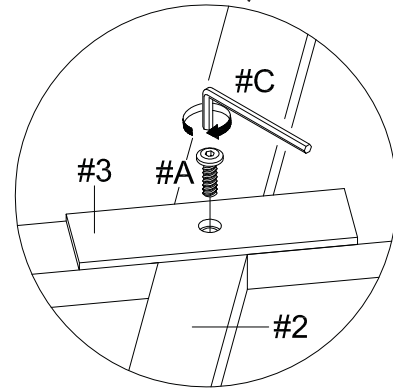
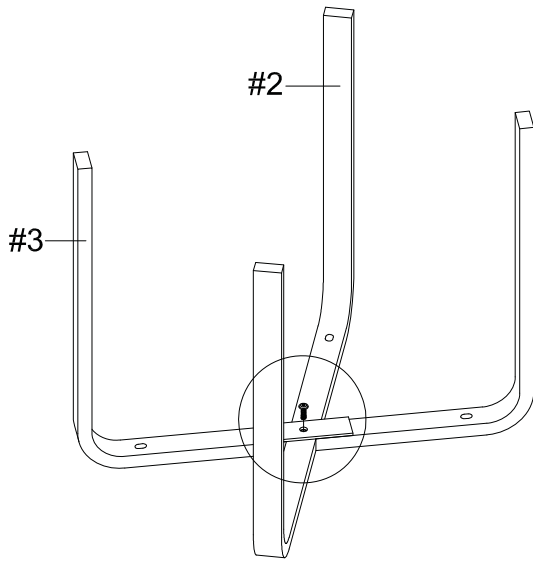

#2

#B x 4pcs  
#D x 4pcs

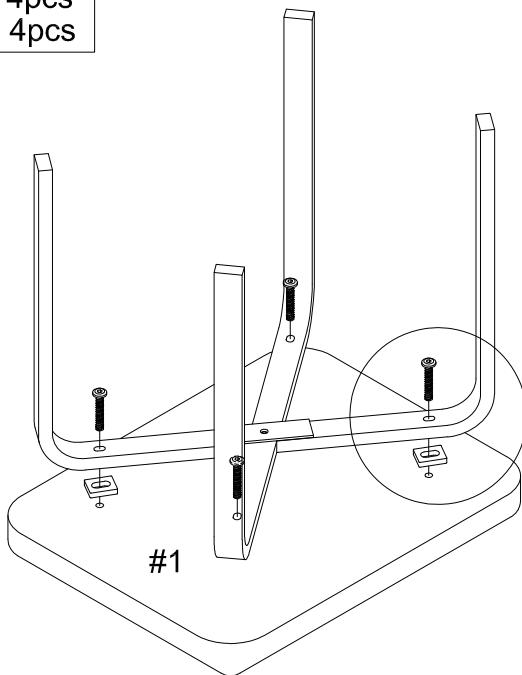
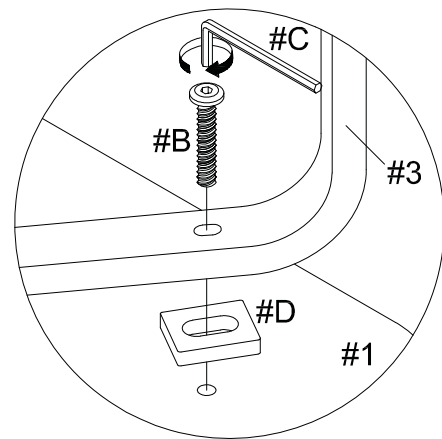

Place the seat (#1) face down, then place a rubber mat (#D) onto each hole. Place the legs face down onto those rubber mats (#D) and insert a bolt (#B) into each hole. Secure using the Allen wrench (#C).

